



**GRAVINER**

Mk7 Oil Mist Detection System



# Mk7 Oil Mist Detection System



High temperatures, in excess of 200°C that occur on bearing surfaces under initial failure conditions, can lead to a rapid generation of oil vapour. When the hot vapour contacts the relatively cooler atmosphere of the crankcase it condenses into a fine mist, with typical particle sizes of around 0.5 to 5 microns in diameter. When the density of these particles reaches between 30 to 50 mg/l (milligrams per litre), depending upon the type of oil, an explosive condition exists.

Oil Mist Detection (OMD) techniques have been used to monitor diesel engine crankcases for potential explosive conditions and early detection of bearing failures. The systems available rely mainly on analysing the optical density of oil mist samples drawn from the crankcase compartments, through pipes to the detector. While these systems proved successful in the past, engine design has improved significantly over the years and oil mist detection techniques have improved substantially to maintain adequate protection.

AREAS OF FAILURE – 2 STROKE ENGINE

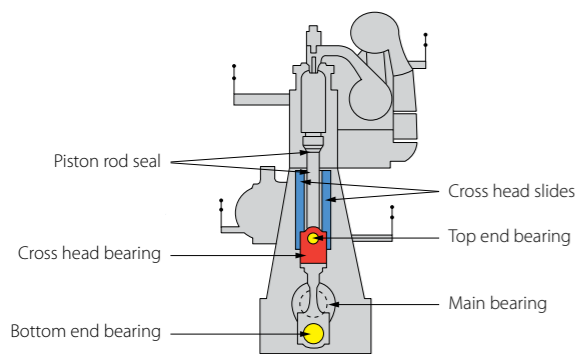

AREAS OF FAILURE – 4 STROKE ENGINE

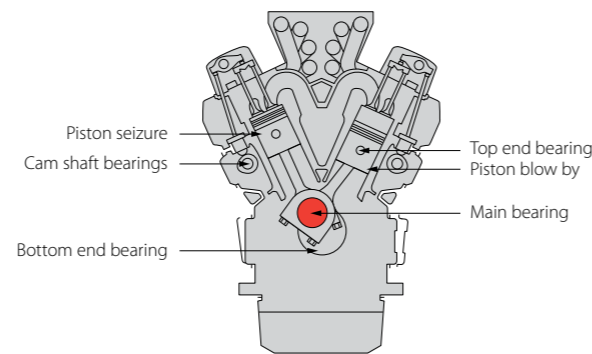

A fire or explosion needs three constituents: fuel, oxygen and an ignition source. Remove one of these and no explosion will occur. Similarly, within the crankcase, the three constituents which could cause an explosion are air, oil mist and an ignition source, the "hot spot". Using optical measuring techniques, oil mist density can be measured at levels as low as 0.05 mg/l and give early warning of a rise in oil mist density.

Under IACS rules, an OMD system is required if any of the following apply:

- Engines above 300mm bore
- Engine output greater than 2,200kW (2,950hp)
- Engine room routinely unmanned

Benefits of the Gravier Mk 7 OMD System include:

- Auto addressed system monitoring up to 10 detector heads per control unit
- Up to 10 control units per single system.
- Suitable for both 2 stroke and 4 stroke engines.
- Elimination of sample pipes - reduced installation costs.
- Engine mounted Control Unit.
- Remote Display Unit mounted in a safe area, typically the Engine Control Room (ECR).

The Gravier Mk7 OMD System is an auto addressed oil mist detection system capable of monitoring up to 10 Control Units per system with each Control Unit having up to 10 detectors connected to it. This is achieved without external sample pipes and with minimum cabling. Each detector head monitors a single crank space and is a stand-alone device. On power up the detectors gather oil mist density data and convert it to a digital signal for transmission via the data lines in the detector cable to the Control Unit which is also mounted on the side of the engine. Alarm levels and Alarm output requirements are all set from either the Remote Indicator Display or a PC connected directly to the control unit.



The Remote Display Unit houses a 7.5" LCD Touch Screen display that shows, on demand, the signal from each detector and indicates the oil mist level for each engine and when required each detector as well as the status of the system. In the event of an alarm, the display immediately shows the oil mist levels for the relevant engine. It also enables the individual readings of each detector on the engine to be displayed on demand and automatically under alarm conditions.



In the event of a detector fault, that detector can be isolated without affecting the function of the other detectors on the engine. The system will continue to operate while the faulty detector is replaced, repaired or maintenance is carried out.

The Mk7 detectors still use optical sensing; (light scatter) as it's detection method and continually monitors the oil mist density in the crank space to which it is connected. In addition, it self checks for any internal faults. The Control Unit interrogates each detector in turn, identifies the position connected at the Control Unit, the oil mist density value and determines the status of the detector.

The Control Unit can be supplied with or without a control membrane. The control membrane has LED indication for detectors connected, push buttons for isolation and de-isolation of detectors, as well as pushbuttons for Accepting and Resetting Alarms.

The Mk7 OMD System is tested and approved in accordance with IACS M67/M10 by the following Class Societies:

- American Bureau of Shipping
- Bureau Veritas
- China Classification Society
- Det Norske Veritas
- Germanischer Lloyd
- Korean Register of Shipping
- Lloyd's Register
- Nippon Kaiji Kyokai
- Polish Register of Shipping
- Registro Italiano Navale
- Russian Maritime Register of Shipping

Also approved by MAN Diesel 2 Stroke and Wartsila 2 Stroke



## Alarm Philosophy

The system has 3 separate alarm levels:

Pre Alarm	This indicates that the oil mist levels are increasing in a particular crank space and that investigation should be undertaken. This alarm will not operate the slowdown or shutdown relays.
High Alarm	When any detector reaches this threshold then the slowdown or shutdown relays will be operated if they are connected.
Back Up Alarm	In the event of a failure of either the Pre Alarm or High Alarm, then the Back Up Alarm will operate, but it will not operate the slowdown or shutdown relay. This is usually connected to a warning beacon or siren; however the customer may choose to connect the relay to another device or the engine slow down circuitry.

On receipt of either a Pre Alarm or High Alarm the engine should, unless connected to a slowdown / shutdown relay, be stopped if safe to do so and allowed to cool down so that the background oil mist levels reduce before entering the engine room.

When the oil mist levels have returned to normal then the Accept and Reset buttons can be operated from the Control Unit membrane if fitted or alternatively form the Remote Display Unit and the system will then return to normal operation.

## Fault Diagnosis

When a system fault is received, the information on the display should be noted and then the appropriate Fault Finding procedure in Chapter 4 of the Manual should be checked to enable the fault to be rectified.

When the faults have been rectified the Accept and Reset buttons can be operated and the system will return to normal

## Event Log

All alarms, faults and events are recorded in an Event Log which is date and time stamped and will indicate the type of event which enables analysis of the events at a later time. The Event Log has a capacity of 1024 events and is a rolling buffer.

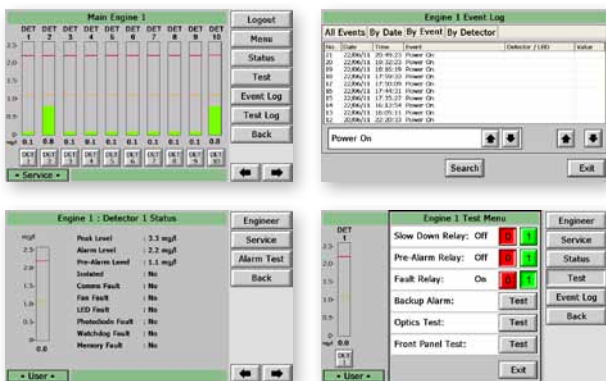

## TECHNICAL SPECIFICATION

### Detector

Mounting	¾ inch BSP
Enclosure Rating	IP65
Material	Sample Tube – Carbon Loaded PTFE Detector – Black Zytel 70G30 Nylon 66
Indicators	Green                      Detector On Red                         Alarm Amber                     Detector Fault
Power Consumption	1.5W
Temperature Rating	0 – 70°C
Height	153mm
Width	90mm
Length	205mm
Weight	0.5kg

### Control Unit

Enclosure Rating	IP65
Material	Aluminium
Max detector inputs	10
Output Relays	Volt-free change over contacts rated at 30Vdc 1A
Back-up Alarm	1 set (de-energised during normal operation)
Pre Alarm	1 set (de-energised during normal operation)
Fault Alarm	1 set (energised during normal operation)
Engine Slowdown / Shutdown	1 set (de-energised during normal operation)
Alarm Ranges	Pre Alarm 0.5mg/l to 1.2mg/l (adjustable) Default Value 0.9mg/l Alarm 1.3mg/l to 2.4mg/l (adjustable) Default Value 1.8mg/l Backup 3.0mg/l (fixed)
Power Consumption	3.9W
Temperature Rating	0 – 70°C
Dimensions	
Height	186mm (110mm mounting centres)
Width	318mm (240mm mounting centres)
Depth	90mm
Weight	2.8kg

### Remote Display Unit

Enclosure Rating	IP32
Material	ABS (PA-765+)
Max No. of detectors	100
Max No. of engines monitored	10
Power Supply	24Vdc (+30% -25%)
Power Consumption	6.0W
Temp Rating	0 – 70°C
Humidity level	95%
Dimensions	
Bulkhead Mounted	Height 225mm (202mm mounting centres) Width 240mm (217mm mounting centres) Depth 58mm
Panel Mounted	Height 225mm (202mm mounting centres) Width 240mm (217mm mounting centres) Depth 55mm Weight 1.0kg